



Shelly 2PM Qubino Wave Instruction Manual

[Home](#) » [Shelly](#) » Shelly 2PM Qubino Wave Instruction Manual 

Shelly
qubino



**2PM Qubino Wave
Instruction Manual**

Contents

- 1 2PM Qubino Wave
- 2 TERMINOLOGY
- 3 INSTALLATION INSTRUCTIONS
- 4 Z-WAVE™ ADDING/REMOVING (INCLUSION/EXCLUSION)
- 5 FACTORY RESET
- 6 Factory reset with the S button:
- 7 LED SIGNALIZATION
- 8 OPERATIONAL INSTRUCTIONS
- 9 SPECIFICATIONS
- 10 IMPORTANT DISCLAIMER
- 11 Documents / Resources
 - 11.1 References

2PM Qubino Wave



Wave 1

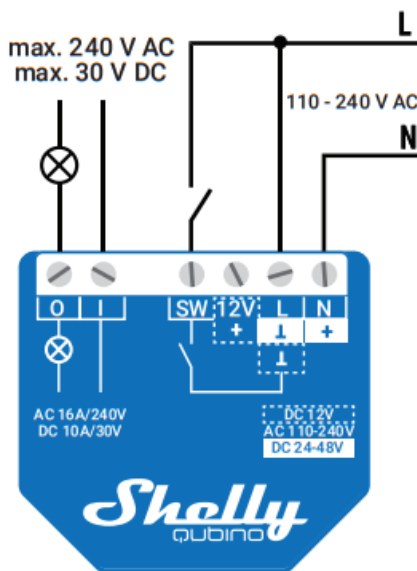

Fig.1/

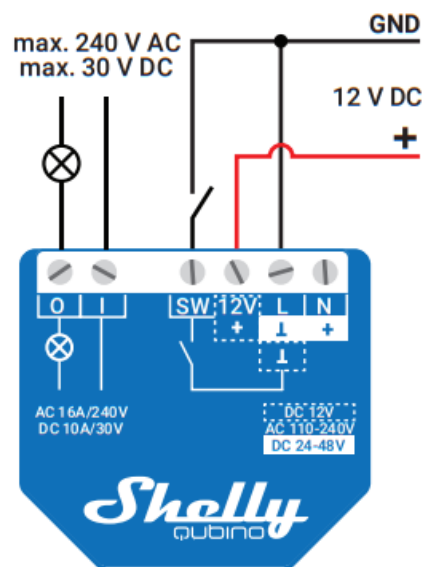

Fig.3/

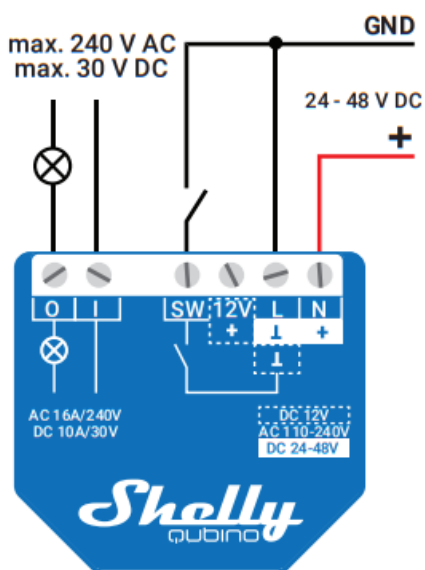

Fig.2/

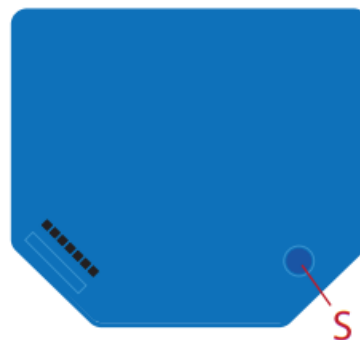

Fig.4/

LEGEND

Device terminals:

- **N**: Neutral terminal

- **L:** Live terminal (110–240 V AC)
- **SW:** Switch/push-button input terminal (controlling O)
- **I:** Load circuit input terminal
- **O:** Load circuit output terminal
- **12V+:** 12 V DC positive terminal
- **+:** 24 – 48 V DC positive terminal
- **⏚:** 12 / 24 – 48 V DC ground terminal
- **S:** S button (Fig. 4)

Wires:

- **N:** Neutral wire
- **L:** Live wire (110-240 V AC)
- **+:** 12 / 24-48 V DC positive wire
- **GND:** 12 / 24-48 V DC ground wire

USER AND SAFETY GUIDE

Z-Wave™ smart switch with potential-free contacts

READ BEFORE USE

This document contains important technical and safety information about the Device, its safe use and installation.

⚠ **CAUTION!** Before beginning the installation, please read carefully and entirely this guide and any other documents accompanying the device. Failure to follow the installation procedures could lead to malfunction, danger to your health and life, violation of law or refusal of legal and/or commercial guarantee (if any). Shelly Europe Ltd. is not responsible for any loss or damage in case of incorrect installation or improper operation of this Device due to failure of following the user and safety instructions in this guide.

TERMINOLOGY

Gateway – A Z-Wave™ gateway, also referred to as a Z-Wave™ controller, Z-Wave™ main controller, Z-Wave™ primary controller, or Z-Wave™ hub, etc., is a device that serves as a central hub for a Z-Wave™ smart home network. The term “gateway” is used in this document. **S button** – The Z-Wave™ Service button, which is located on Z-Wave™ devices and is used for various functions such as adding (inclusion), removing (exclusion), and resetting the device to its factory default settings. The term “S button” is used in this document.

Device – In this document, the term “**Device**” is used to refer to the Wave 1 device.

ABOUT SHELLY QUBINO

Shelly Qubino is a line of innovative microprocessor-managed devices, which allow remote control of electric circuits with a smartphone, tablet, PC, or home automation system. They work on Z-Wave™ wireless communication protocol, using a gateway. When the gateway is connected to the internet, you can control Shelly Qubino devices remotely from anywhere. Shelly Qubino devices can be operated in any Z-Wave™ network with other Z-Wave™ certified devices from other manufacturers. All mains operated nodes within the network will act as repeaters regardless of vendor to increase reliability of the network. Devices are designed to work with older generations of Z-Wave™ devices and gateways.

ABOUT THE WAVE 1

The Wave 1 (Device) controls on/off function for one electrical device, e.g., bulb, ceiling fan, IR heater, electrical locks, garage doors, irrigation system, etc. The output contact is potential-free (dry contact), so different power supply loads (up to 16 A) can be connected to the Device. It is compatible with push-buttons and switches (default).

ELECTRICAL DIAGRAM (110-240 V AC / 24-48 V DC / 12 V DC)

Refer to the schematics (Fig. 1-3) in this user guide.

INSTALLATION INSTRUCTIONS

The Device can control a various type of loads (e.g., bulbs) in one electrical circuit up to 3.5 kW / 240 V AC. It can be retrofitted into standard electrical wall boxes, behind power sockets and light switches or other places with limited space.

⚠ **CAUTION!** Danger of electrocution. Mounting/installation of the Device to the power grid has to be performed with caution, by a qualified electrician.

⚠ **WARNING!** Danger of electrocution. Every change in the connections has to be done after ensuring there is no voltage present at the Device terminals.

⚠ **CAUTION!** Use the Device only with a power grid and appliances that comply with all applicable regulations. A short circuit in the power grid or any appliance connected to the Device may damage it.

⚠ **CAUTION!** Do not connect the Device to appliances exceeding the given max. load!

⚠ **CAUTION!** Do not shorten the antenna.

⚠ **RECOMMENDATION:** Place the antenna as far away as possible from metal elements as they can cause signal interference.

⚠ **CAUTION!** Connect the Device only in the way shown in these instructions. Any other method could cause damage and/or injury.

⚠ **CAUTION!** Do not install the Device where it can get wet.

⚠ **CAUTION!** Do not use the Device if it has been damaged!

⚠ **CAUTION!** Do not attempt to service or repair the Device yourself!

⚠ **RECOMMENDATION:** Connect the Device using solid single-core wires with increased insulation heat resistance not less than PVC T105°C (221°F).

⚠ **CAUTION!** Before starting the mounting/installation of the Device, check that the breakers are turned off and there is no voltage on their terminals. This can be done with a phase tester or multimeter. When you are sure that there is no voltage, you can proceed to connecting the wires.

Connect the load circuit to the Device I and O terminals.

If you are using AC power supply for the Device, connect the Live wire to the Device L terminal, and the Neutral wire to the N terminal as shown on Fig. 1. Connect a switch or a push-button to the Device SW terminal and the Live wire.

If you are using 24-48 V DC power supply (Fig. 2), connect the + wire to the + and the GND wire to the terminal of the Device.

If you are using stabilized 12 V DC power supply (Fig. 3), connect the + wire to the 12V+ terminal, instead to the + terminal. Connect the switch/push-button to the "SW" terminal and the GND wire.

⚠ **RECOMMENDATION:** For inductive appliances that cause voltage spikes during switching on/off, such as electrical motors, fans, vacuum cleaners and similar ones, RC snubber (0.1 μF / 100 Ω / 1/2 W / 600 VAC) should be connected parallel to the appliance.

⚠ **CAUTION!** Do not allow children to play with the push-buttons/ switches connected to the Device. Keep the devices for remote control of Shelly Qubino (mobile phones, tablets, PCs) away from children.

Z-WAVE™ ADDING/REMOVING (INCLUSION/EXCLUSION)

SmartStart adding (inclusion):

SmartStart enabled products can be added into a Z-Wave™ network by scanning the Z-Wave™ QR Code present on the Device with a gateway providing SmartStart inclusion. No further action is required, and the SmartStart device will be added automatically within 10 minutes of being switched on in the network vicinity.

1. With the gateway application scan the QR code on the Device label and add the Security 2 (S2) Device Specific Key (DSK) to the Provisioning List in the gateway.
2. Connect the Device to a power supply.
3. Check if the blue LED is blinking in Mode 1. If so, the Device is not added to a Z-Wave™ network.
4. Adding will be initiated automatically within a few seconds after connecting the Device to a power supply, and the Device will be added to a Z-Wave™ network automatically.
5. The blue LED will be blinking in Mode 2 during the adding process.
6. The load connected to O will be blinking 1s on/1s off/1s on/1s off if the Device is successfully added to a Z-

Wave™ network.

7. The green LED will be blinking in Mode 1 if the Device is successfully added to a Z-Wave™ network.

Adding (inclusion) with a switch/push-button:

1. Connect the Device to a power supply.
2. Check if the blue LED is blinking in Mode 1. If so, the Device is not added to a Z-Wave™ network.
3. Enable add/remove mode on the gateway.
4. Toggle the switch/push-button connected to the SW terminal 3 times within 3 seconds (this procedure puts the Device in LEARN MODE*). The Device must receive on/off signal 3 times, which means pressing the push-button 3 times, or toggling the switch on and off 3 times.
5. The blue LED will be blinking in Mode 2 during the adding process.
6. The load connected to O will be blinking 1s on/1s off/1s on/1s off if the Device is successfully added to a Z-Wave™ network.
7. The green LED will be blinking in Mode 1 if the Device is successfully added to a Z-Wave™ network. *LEARN MODE state allows the Device to receive network information from the gateway.

Adding (inclusion) with the S button:

1. Connect the Device to a power supply.
2. Check if the blue LED is blinking in Mode 1. If so, the Device is not added to a Z-Wave™ network.
3. Enable add/remove mode on the gateway.
4. To enter the Setting mode, quickly press and hold the S button on the Device until the LED turns Solid blue.
5. Quickly release and then press and hold (> 2 s) the S button on the Device until the blue LED starts blinking in Mode 3. Releasing the S button will start the LEARN MODE.
6. The blue LED will be blinking in Mode 2 during the adding process.
7. The load connected to O will be blinking 1s on/1s off/1s on/1s off if the Device is successfully added to a Z-Wave™ network.
8. The green LED will be blinking in Mode 1 if the Device is successfully added to a Z-Wave™ network.

Note! In Setting mode, the Device has a timeout of 10s before entering again into Normal mode.

Note! In case of Security 2 (S2) adding (inclusion), a dialog will appear asking you to enter the corresponding PIN code (5 underlined digits) that are written on the DSK label on the side of the Device and on the DSK label inserted in the packaging.

IMPORTANT: The PIN code must not be lost.

Removing (exclusion) with a switch/push-button:

1. Connect the Device to a power supply.
2. Check if the green LED is blinking in Mode 1. If so, the Device is added to a Z-Wave™ network.
3. Enable add/remove mode on the gateway.
4. Toggle the switch/push-button connected to the SW terminal 3 times within 3 seconds (this procedure puts the Device in LEARN MODE*). The Device must receive on/off signal 3 times, which means pressing the push-button 3 times, or toggling the switch on and off 3 times.
5. The blue LED will be blinking in Mode 2 during the removing process.
6. The load connected to O will be blinking 1s on/1s off/1s on/1s off if the Device is successfully removed from a Z-

Wave™ network.

7. The blue LED will be blinking in Mode 1 if the Device is successfully removed from a Z-Wave™ network.

Removing (exclusion) with the S button:

1. Connect the Device to a power supply.
2. Check if the green LED is blinking in Mode 1. If so, the Device is added to a Z-Wave™ network.
3. Enable add/remove mode on the gateway.
4. To enter the Setting mode, quickly press and hold the S button on the Device until the LED turns Solid blue.
5. Quickly release and then press and hold (> 2s) the S button on the Device until the blue LED starts blinking in Mode 3. Releasing the S button will start the LEARN MODE.
6. The blue LED will be blinking in Mode 2 during the removing process.
7. The load connected to O will be blinking 1s on/1s off/1s on/1s off if the Device is successfully removed from a Z-Wave™ network.
8. The blue LED will be blinking in Mode 1 if the Device is successfully removed from a Z-Wave™ network.
Note! In Setting mode, the Device has a timeout of 10s before entering again into Normal mode.

FACTORY RESET

After Factory reset, all custom parameters and stored values (associations, routings, etc.) will return to their default state. HOME ID and NODE ID assigned to the Device will be deleted. Use this reset procedure only when the gateway is missing or otherwise inoperable.

Factory reset with a switch/push-button:

Note! Factory reset with the switch/push-button is only possible within the first minute after the Device is connected to a power supply.

1. Connect the Device to a power supply.
2. Toggle the switch/push-button connected to the SW terminal 5 times within 3 seconds. The Device must receive on/off signal 5 times, which means pressing the push-button 5 times, or toggling the switch on and off 5 times.
3. During factory reset, the LED will turn solid green for about 1s, then the blue and red LED will start blinking in Mode 3 for approx. 2s.
4. The blue LED will be blinking in Mode 1 if the Factory reset is successful.

Factory reset with the S button:

Note! Factory reset with the S button is possible anytime.

1. To enter the Setting mode, quickly press and hold the S button on the Device until the LED turns Solid blue.
2. Press the S button multiple times until the LED turns Solid red.
3. Press and hold (> 2s) S button on the Device until the red LED starts blinking in Mode 3. Releasing the S button will start the factory reset.
4. During factory reset, the LED will turn solid green for about 1s, then the blue and red LED will start blinking in Mode 3 for approx. 2s.
5. The blue LED will be blinking in Mode 1 if the Factory reset is successful.

NOTE: For more information about this Device refer to the Extended User Guide available at:

LED SIGNALIZATION

LED blinking modes	
Mode 1	0,5s On/2s Off
Mode 2	0,5s On/0,5s Off
Mode 3	0,1s On/0,1s Off
Mode 4	(1x to 6x – 0,2s On/0,2s Off) + 2s Off

Normal mode	Colour	LED mode
Removed/Excluded	Blue	Mode 1
Added/Included	Green	Mode 1
Setting mode (with S button)		
Adding/Removing (Inclusion/Exclusion) menu selected	Blue	Solid
Adding/Removing (Inclusion/Exclusion) menu – while pressing S button -Adding/Removing (Inclusion/Exclusion) process selected	Blue	Mode 3
Factory reset menu selected	Red	Solid
Factory reset – while pressing S button – Factory reset process selected	Red	Mode 3
“Setting in progress” mode		
Factory reset and reboot	Blue/ Red/ Green	**
Adding/Removing (Inclusion/Exclusion)	Blue	Mode 2
OTA firmware updating	Blue/ Red	Mode 2
Alarm mode		
Overheat detected	Red	Mode 4(2x)

** The LED will turn solid green for about 1s, then the blue and red LED will start blinking in Mode 3 for approx. 2s. LED will turn off 30 minutes after the power cycle. Every time you press on the S button, the LED will turn on for 30 minutes. If alarm is active, LED will not turn off.

OPERATIONAL INSTRUCTIONS

If the SW is configured as a switch (default), each toggle of the switch will change the output O state to the opposite state – on, off, on, etc.

If the SW is configured as a push-button in the Device settings, each press of the push-button will change the output O state to the opposite state – on, off, on, etc.

SUPPORTED LOAD TYPES

- Resistive (incandescent bulbs, heating devices)
- Capacitive (capacitor banks, electronic equipment, motor start capacitors)
- Inductive with RC Snubber (LED light drivers, transformers, fans, refrigerators, air-conditioners)

SPECIFICATIONS

Power supply	110-240 V AC / 24-48 V DC / 12 V DC \pm 10%
Power consumption	< 0.3 W
Max. switching voltage AC	240 V
Max. switching current AC	16 A
Max. switching voltage DC	30 V
Max. switching current DC	10 A
Overheating protection	Yes
Distance	Up to 40 m indoors (131 ft.) (depends on local condition)
Z-Wave repeater	Yes
CPU	Z-Wave S800
Z-Wave frequency bands	868,4 MHz; 865,2 MHz; 869,0 MHz; 921,4 MHz; 908,4 MHz; 916 MHz; 919,8 MHz; 922,5 MHz; 919,7-921,7-923,7 MHz; 868,1 MHz; 920,9 MHz
Maximum radio frequency power transmitted in frequency band(s)	< 25 mW
Size (H x W x D)	37x42x16 \pm 0.5 mm / 1.46x1.65x0.63 \pm 0.02 in
Weight	26 g / 0.92 oz.
Mounting	Wall console
Screw terminals max. torque	0.4 Nm / 3.5 blin
Conductor cross section	0.5 to 1.5 mm ² / 20 to 16 AWG
Conductor stripped length	5 to 6 mm / 0.20 to 0.24 in
Shell material	Plastic
Color	Blue
Ambient temperature	-20°C to 40°C / -5°F to 105°F
Humidity	30% to 70% RH
Max. altitude	2000 m / 6562 ft.

IMPORTANT DISCLAIMER

Z-Wave™ wireless communication may not always be 100% reliable. This Device should not be used in situations in which life and/or valuables are solely dependent on its functioning. If the Device is not recognized by your gateway or appears incorrectly, you may need to change the Device type manually and ensure that your gateway

supports Z-Wave Plus™ multi-level devices.

ORDERING CODE: **QNSW-001X16XX**

XX – Values define product version per region.

DECLARATION OF CONFORMITY

Hereby, Shelly Europe Ltd. (former Alterio Robotics EOOD) declares that the radio equipment type Wave 1 is in compliance with Directive 2014/53/EU, 2014/35/EU, 2014/30/EU, 2011/65/EU. The full text of the EU declaration of conformity is available at the following internet address: <https://shelly.link/Wave1-DoC>

MANUFACTURER:

Shelly Europe Ltd.

Address: 103 Chernivrah Blvd., 1407 Sofia, Bulgaria

Tel.: +359 2 988 7435

E-mail: zwave-shelly@shelly.cloud

Support: <https://support.shelly.cloud/>

Web: <https://www.shelly.com>

Changes in the contact data are published by the Manufacturer at the official website: <https://www.shelly.com>



Documents / Resources



[Shelly 2PM Qubino Wave](#) [pdf] Instruction Manual
2PM Qubino Wave, 2PM, Qubino Wave, Wave

References

- [🇬🇧 Welcome to Shelly Knowledge Base!](#)
- [🔗 shelly.link/Wave1-DoC](https://shelly.link/Wave1-DoC)
- [📄 Support](#)
- [🔗 Shelly - Explore the possibilities.](#)
- [📖 User Manual](#)

[Manuals+](#), [Privacy Policy](#)

This website is an independent publication and is neither affiliated with nor endorsed by any of the trademark owners. The "Bluetooth®" word mark and logos are registered trademarks owned by Bluetooth SIG, Inc. The "Wi-Fi®" word mark and logos are registered trademarks owned by the Wi-Fi Alliance. Any use of these marks on this website does not imply any affiliation with or endorsement.